

NOTE: BREAK ALL CORNERS WITH 0.015" (.38 MM) RADIUS UNLESS OTHERWISE NOTED. STANDARD TOLERANCES TO APPLY UNLESS OTHERWISE SPECIFIED.

CUSTOMER		CAN ART STD.		DIE No.	EH61843	REV. No.	2
DESCRIPTION			CUSTOMER PART No.	QUOTE No.	PROPOSAL No.		
2.500 x 0.187 SQ. TUBE w/ ROUND CORNERS				08-0164-1	H-18867		

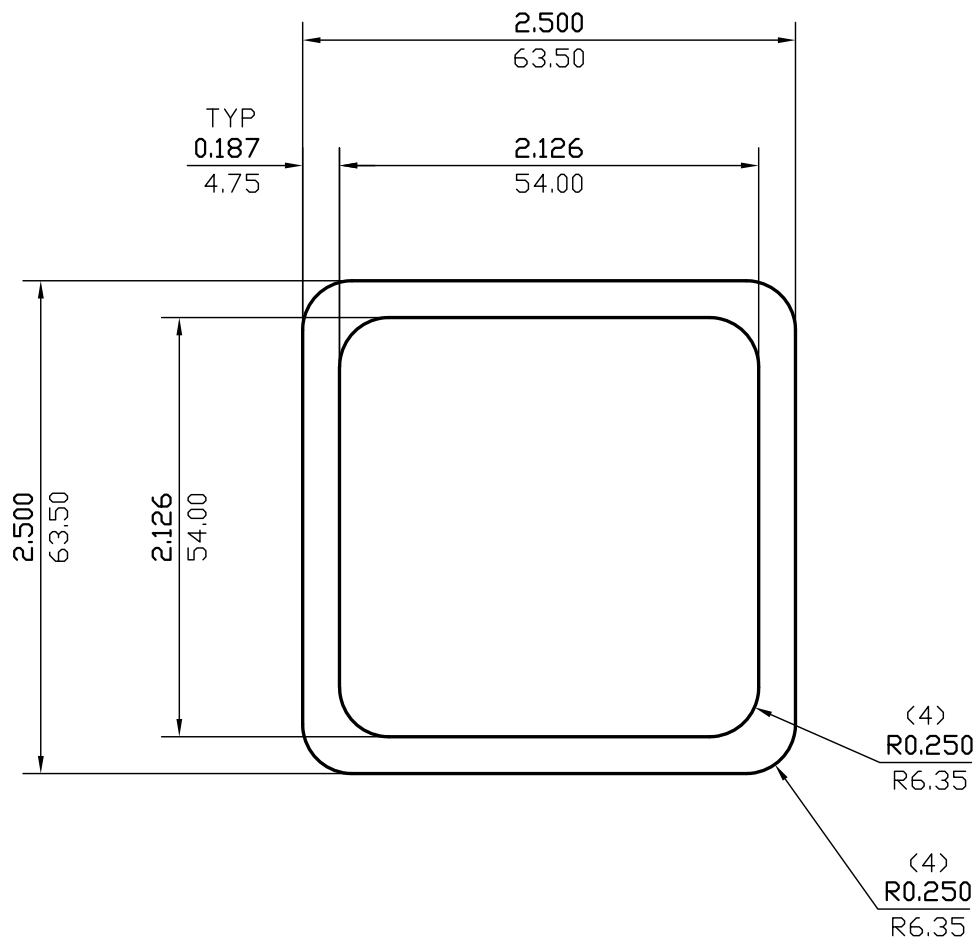

WALL THICKNESS 0.187 (4.75) EXCEPT AS SHOWN

DATE	REV	DESCRIPTION	BY
03/13/23	2	REMOVED ALLOY	JASON
01/12/10	1	CHANGED CUST. NAME.	PAUL
EST.AREA	1.730	IN. ²	EST.AREA 1116.216
			MM. ²
EST.WT.	2.042	LBS/FT.	EST.WT. 3.038
			KG/M.
EST.PER.	17.646	IN.	EST.PER. 448.198
			MM.
OUT PER.	9.571	IN.	OUT PER. 243.1
			MM.
C.C.D.	3.328	IN.	C.C.D. 84.542
			MM.
FINISH	M/F		ALLOY
CKD BY	FACTOR 9	SCALE 1:1	DWN BY P.M. DATE 03/18/2008

CAN ART

85 PARKSHORE DRIVE
BRAMPTON, ONT L6T 5M1
TEL. NO. (905) 791-1464
FAX NO. (905) 791-9151
WEB: www.canart.com

ALUMINUM EXTRUSION INC.

THIS DRAWING IS NOT NECESSARILY A COPY OF YOUR ORIGINAL. PLEASE APPROVE DIMENSIONS AND TOLERANCES INDICATED. CAN ART ASSUMES NO RESPONSIBILITY EITHER TECHNICAL OR LEGAL FOR HAVING THIS SHAPE MADE. THE CUSTOMER AGREES TO FULLY PROTECT CAN ART ALUMINUM FROM CLAIMS OF OTHERS RESULTING FROM THIS SHAPE.

SIGNED: _____ DATE: _____